

REMER

RUBINETTERIE

SOFFIONE A SOFFITTO CON GETTO A PIOGGIA E FARETTO PER CROMOTERAPIA, ISPEZIONABILE, ACCIAIO INOX LUCIDATO A SPECCHIO. SISTEMA DI MONTAGGIO "EASY FIX". PULSANTIERA A PARETE INCLUSA.

CEILING SHOWERHEAD WITH RAIN JET AND SPOTLIGHT FOR CHROMOTHERAPY, INSPECTABLE, MIRROR-POLISHED STAINLESS STEEL. "EASY FIX" MOUNTING SYSTEM. WALL PUSHBUTTON PANEL INCLUDED.

art. 357REFS34 / 357REFS44 / 357REFM34 / 357REFM44

IT | Istruzioni di montaggio
EN | Assembly Instructions

Remer Rubinetterie S.p.A.

20062 Via Leonardo da Vinci, 83 - Cassano d'Adda (MI) Italy
Tel. +39 0363 364211 - e-mail: info@remer.eu
www.remer.eu

Dimensioni generali/General dimensions/Allgemeine Abmessungen/ Dimensions générales

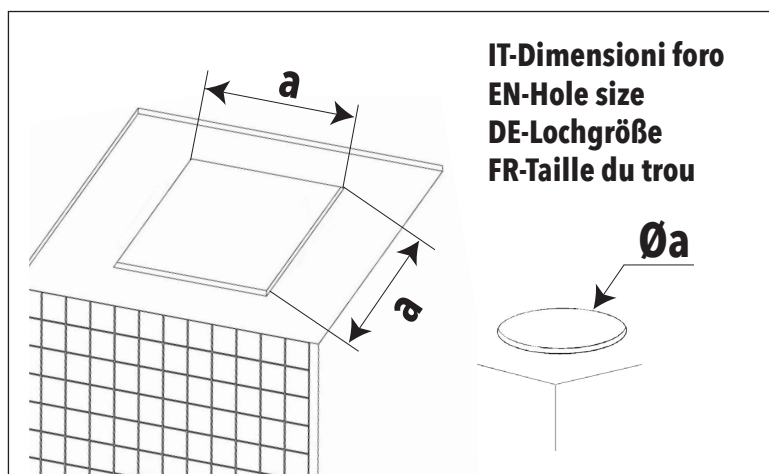
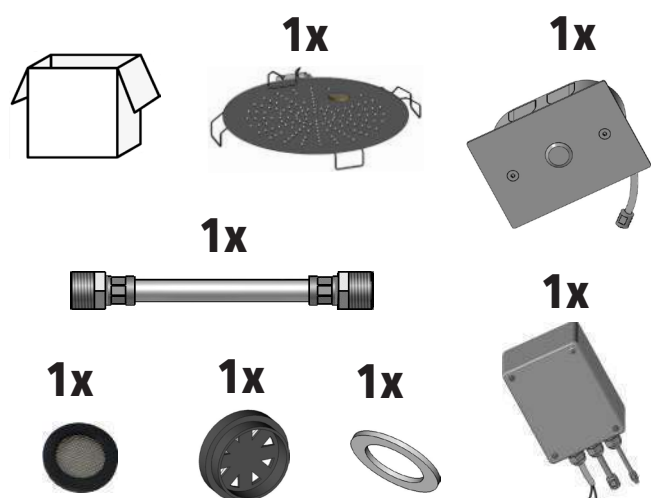
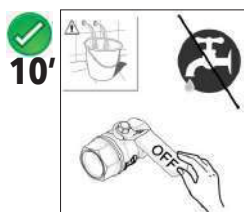
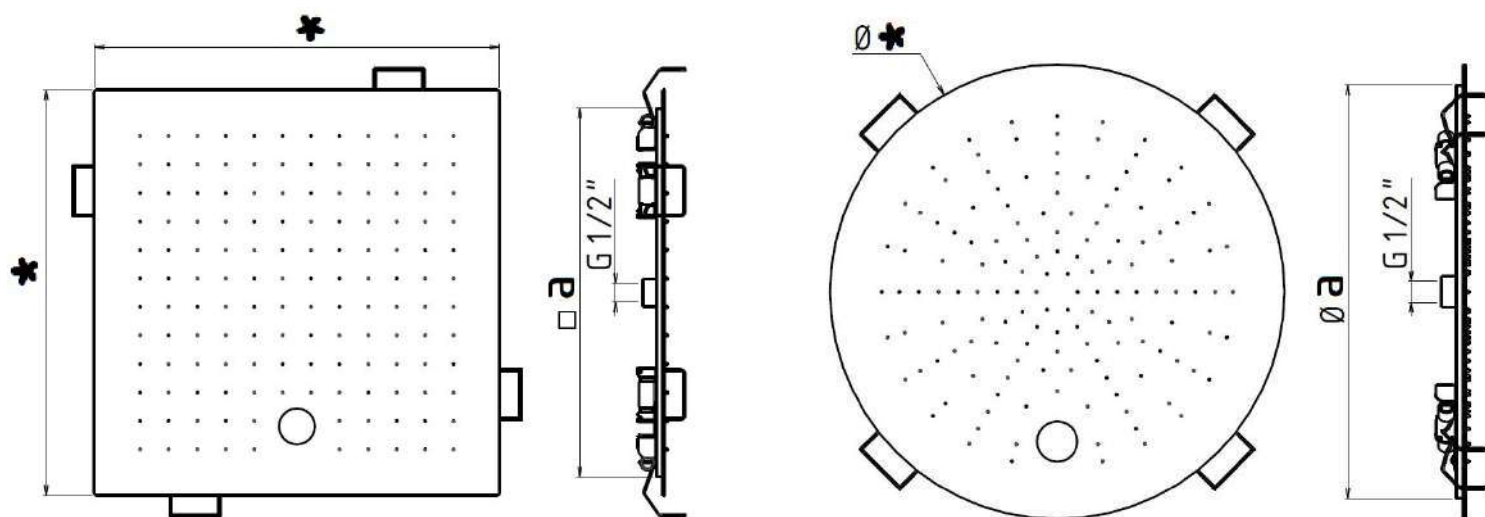

(*)Dimensioni esterne prodotto (mm) External product size (mm) Externe Produktgröße (mm) Dimensions extérieures du produit (mm)	(a)Dimensioni min. foro controsoffitto (mm) Min size false ceiling hole (mm) Mindestgröße Zwischendecke Loch (mm) Taille min. trou de faux plafond (mm)	(a)Dimensioni Max. foro controsoffitto (mm) Dimensions Max. Ceiling hole (mm) Abmessungen Max. Deckenloch (mm) Dimensions Trou plafond max (mm)
Ø340	Ø300	Ø310
Ø440	Ø400	Ø410
340x340	300x300	310x310
440x440	400x400	410x410



IT - L'apparecchio deve essere installato da personale abilitato ai sensi e per l'effetto delle leggi in vigore.
 EN - According to the law, all installation and maintenance operations require a qualified person.
 DE - Das Gerät muss von qualifiziertem Personal gemäß den geltenden Gesetzen installiert werden.
 FR - L'appareil doit être installé par du personnel qualifié conformément et pour l'effet des lois en vigueur.

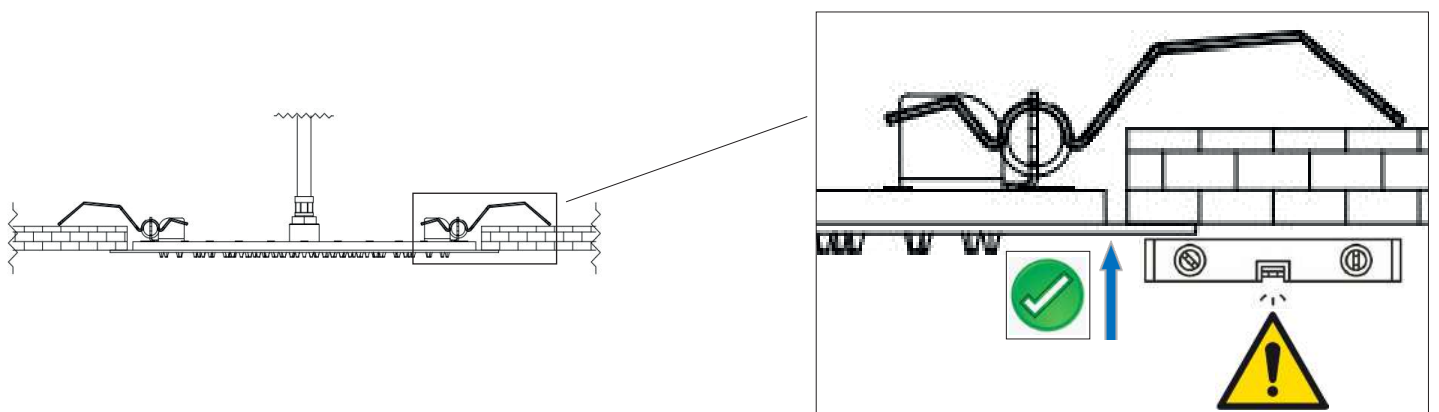
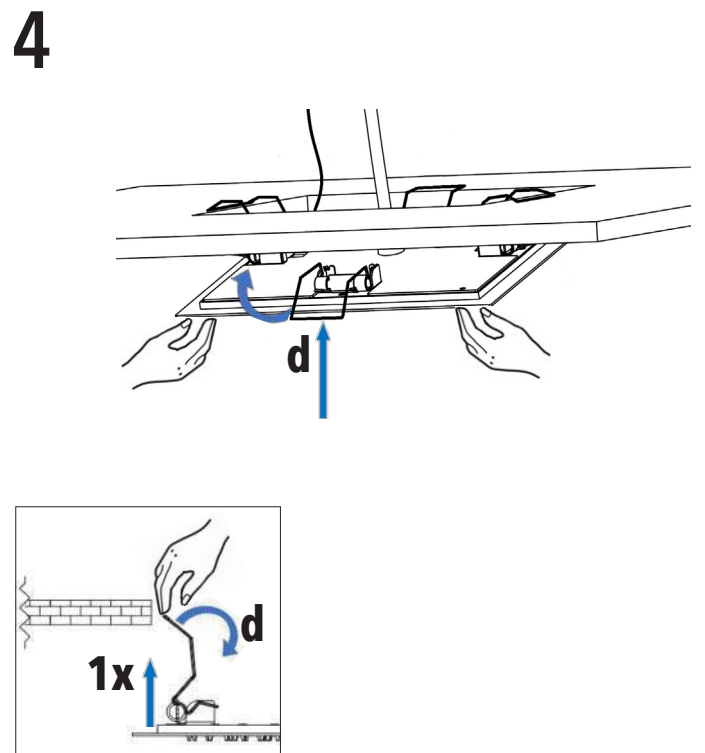
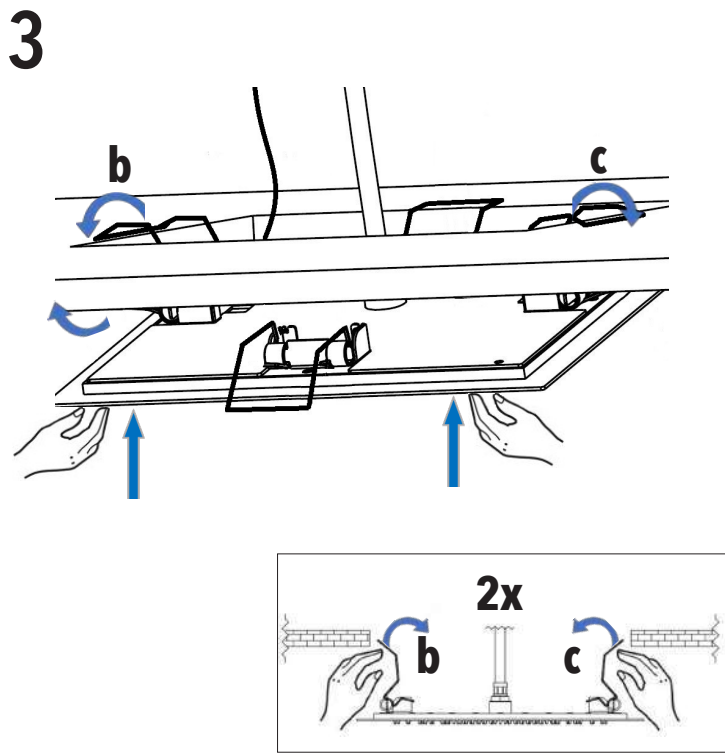
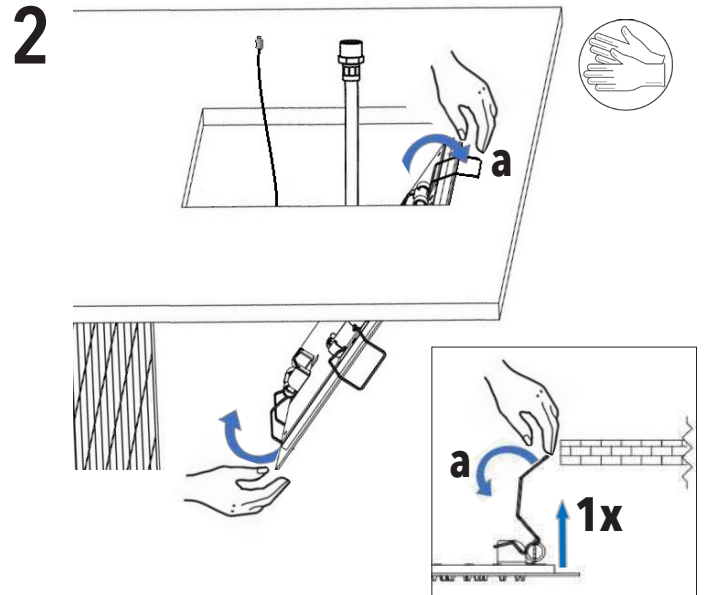
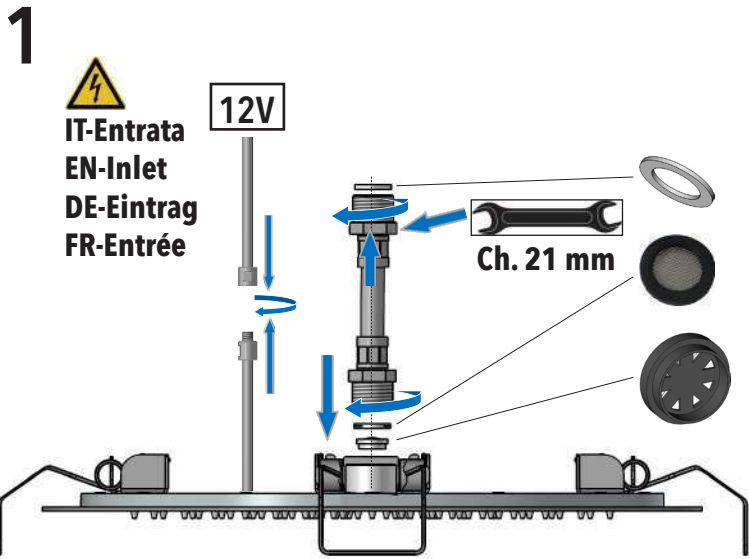



IT - Il soffione può essere ispezionabile per la pulizia.
 EN - The shower head can be inspected for cleaning.
 DE - Der Duschkopf kann zur Reinigung inspiziert werden.
 FR - La pomme de douche peut être inspectée pour le nettoyage.

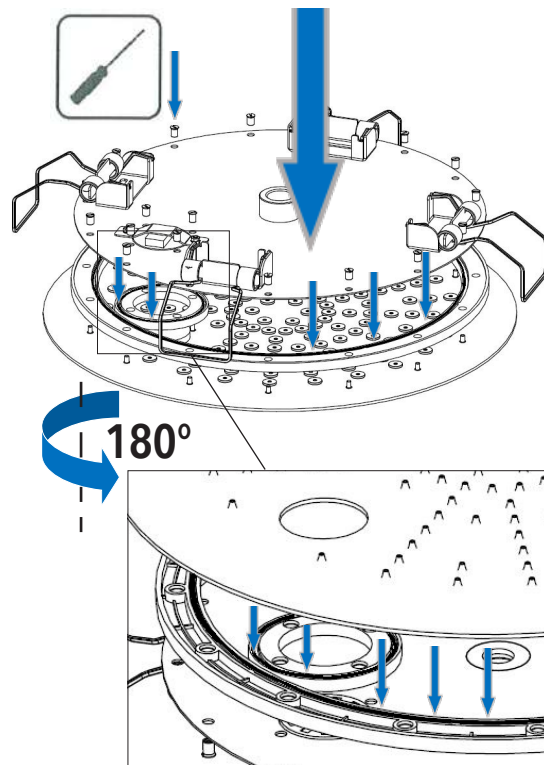
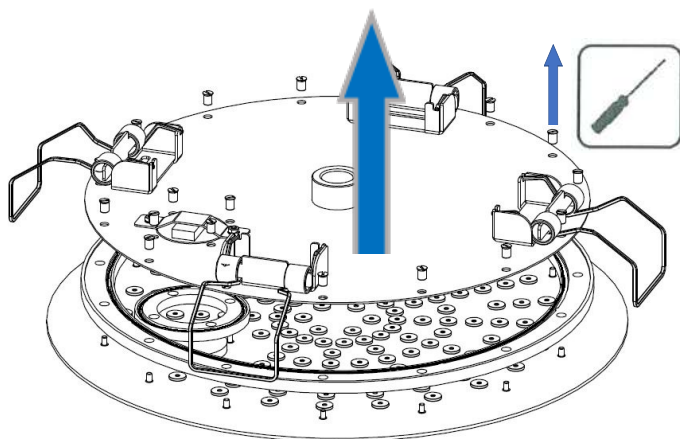

IT - Verificare che gli O-Ring sia nella sede.
 EN - Verify that the O-rings are in place.
 DE - Stellen Sie sicher, dass die O-Ringe vorhanden sind.
 FR - Vérifiez que les joints toriques sont en place.

CROMOTERAPIA - CHROMOTHERAPY - FARB THERAPIE - CHROMOTHÉRAPIE

IT - Comando incasso a muro
 EN - In-wall control
 DE - Wandeinbau
 FR - Commande encastrée au mur



IT - Prima di qualsiasi operazione togliere sempre la tensione all'impianto.
 EN - Always turn voltage off before performing any operation on the electric system.
 DE - Vor jedem Vorgang immer die Spannung der elektrischen Anlage entfernen.
 FR - Coupez toujours la tension avant d'effectuer toute opération.

IT - Installare l'alimentatore Class 2 - 12 Vac +/- 3% - Min. 35 VA nella zona 3 conforme alle distanze di sicurezza previste dalle normative CEI.

EN - Install the Class 2 - 12 Vac +/- 3% - Min. 35 VA device in zone 3, as per the IEC regulations about safety distance.

DE - Installieren Sie das Netzteil der Klasse 2 - 12 V DC +/- 3% - Min. 35 VA in Zone 3 gemäß den Sicherheitsabständen, die in den CEI-Vorschriften vorgeschrieben sind.

FR - Installez l'appareil Classe 2 - 12 Vca +/- 3% - Min. 35 VA dans la zone 3 en respectant les réglementations CEI sur la distance de sécurité.

IT - Collegamento elettrico
EN - Electrical connection setup
DE - Aufbau der elektrischen Verbindung
FR - Configuration de la connexion électrique

IT-Tensione EN-Voltage DE-Stromspannung FR-Tension	Frequenza Frequency DE-Frequenz La fréquence	Potenza nominale Max. Max. rated power input Max. spezifizierte Leistung Max. puissance d'entrée nominale	Grado di protezione parti elettriche Protection level of electrical parts Schutzgrad für elektrische Teile Niveau de protection des pièces électriques	Grado di protezione pulsante Button protection level Schutzgradknopf Niveau de protection des boutons
100-240 VAC	50-60 Hz	30 W	IP55	IP64

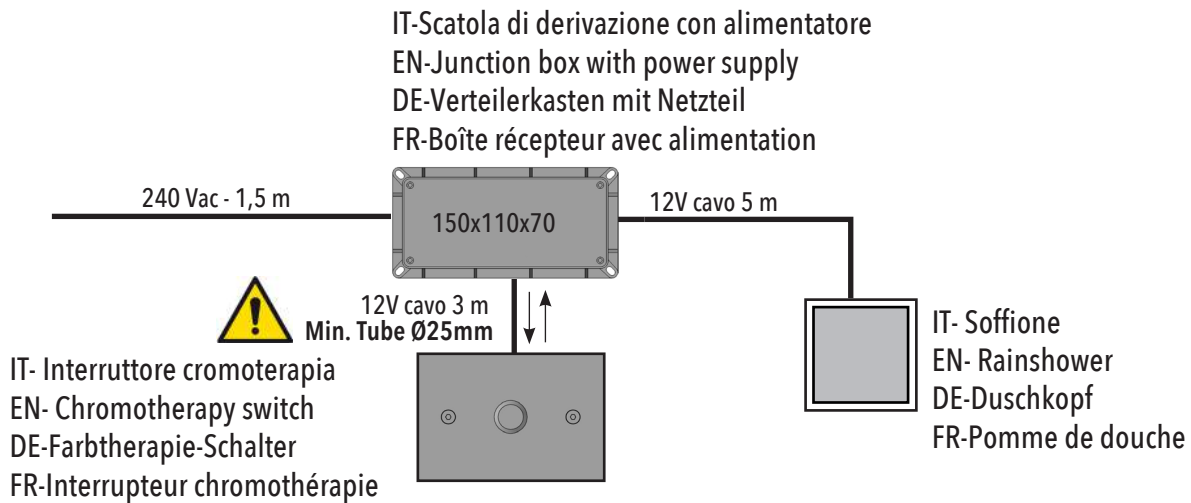

IT-Modalità di funzionamento LED RGB

EN-Mode of operation of the RGB LED

DE-Funktionsweise der RGB-LED

FR-Mode de fonctionnement de la LED RVB

IT- Sequenza colori: Bianco - Rosso - Verde - Blu - Giallo - Fucsia - Azzurro.

EN- Color sequence: White - Red - Green - Blue - Yellow - Fuchsia - Bright Blue.

DE-Farbfolge: Weiß - Rot - Grün - Blau - Gelb - Fuchsia - Hellblau.

FR-Séquence de couleurs: blanc - rouge - vert - bleu - jaune - fuchsia - bleu vif.

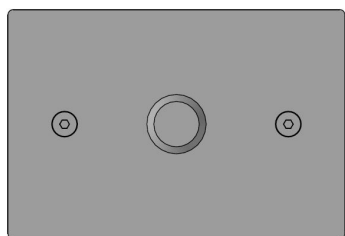

IT- Premere una volta il tasto: ACCESO.

EN- Press the key once: POWER ON.

DE- EDrücken Sie die Taste einmal: EINGESCHALTET.

FR- Appuyez une fois sur la touche : ALLUMÉ.

IT- Ripremere il tasto: Scelta manuale del colore.

EN- Press the button again: Manual color selection.

DE- Drücken Sie die Taste erneut: Manuelle Auswahl der Farbe.

FR- Appuyez à nouveau sur le bouton: Choix de couleur.

IT- Premi per 2 secondi il tasto: Cromoterapia modalità automatica, rotazione colori come sequenza ogni minuto.

EN- Press the button for 2 seconds: Automatic chromotherapy, color rotation every minute following the sequence above.

DE- Drücken Sie die Taste für 2 Sekunden: Automatische Farbtherapie, Farbrotaion als Sequenz jede Minute.

FR- Appuyez sur le bouton pendant 2 secondes : Chromothérapie mode automatique, rotation des couleurs en séquence toutes les minutes.

IT- Premere 2 volte consecutivamente il tasto: SPENTO.

EN- Press the button twice consecutively: TURNED OFF.

DE- Drücken Sie die Taste zweimal hintereinander: AUSGESCHALTET.

FR- Appuyez sur le bouton deux fois de suite: ÉTEINDRE.

IT- Predisposizione elettrica consigliata.
EN- Electrical preparation recommended.
DE- Elektrische Vorbereitung empfohlen.
FR- Préparation électrique recommandée.

IT- Soffione
 EN- Rainshower
 DE- Duschkopf
 FR- Pomme de douche

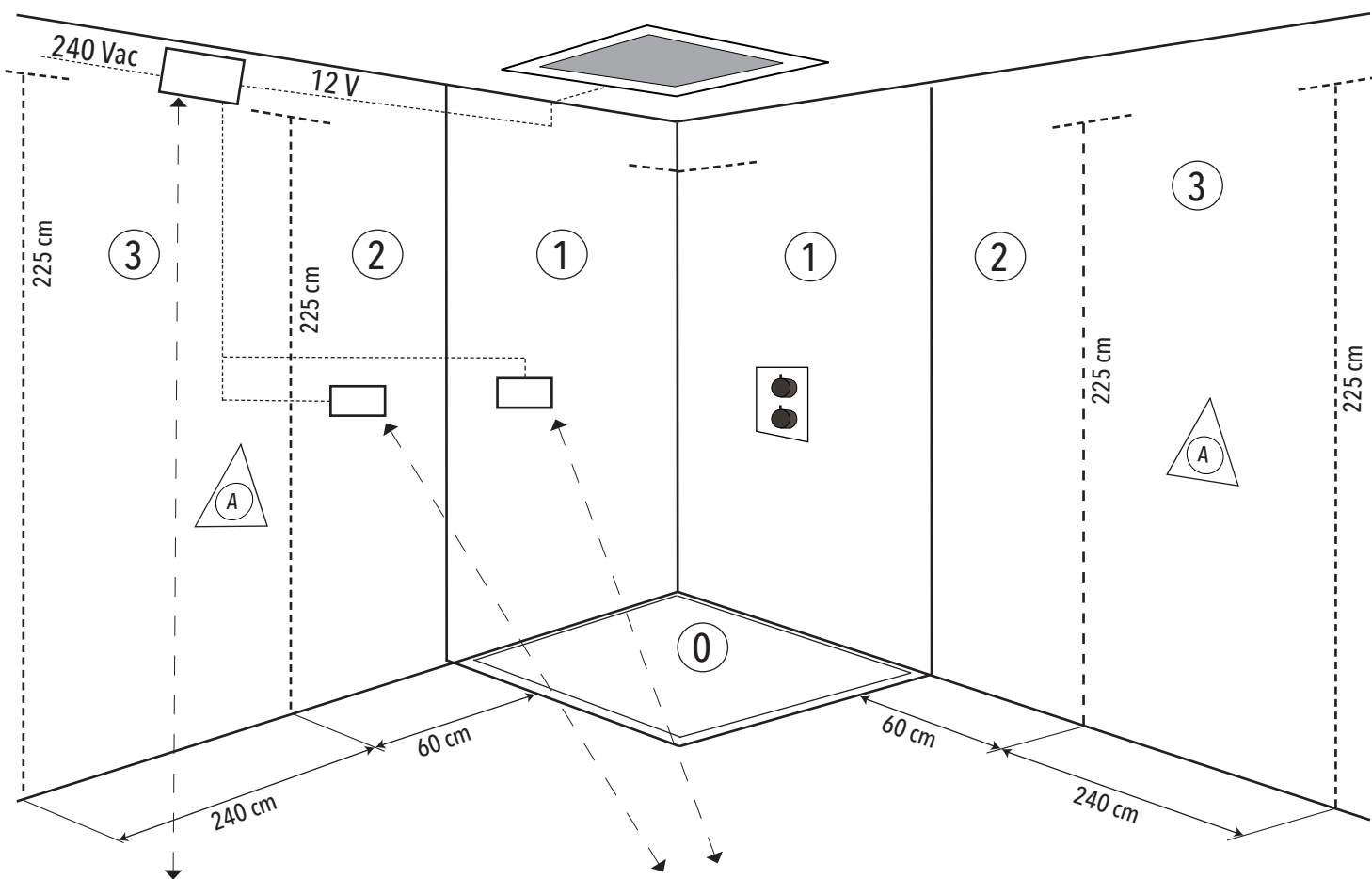

IT- SCATOLA DI DERIVAZIONE

Ipotetica posizione per scatola di derivazione (cavo di 1,5 m 240Vac, esterna a cabina doccia).

EN- JUNCTION BOX

Ideal position of the in-wall junction box (cable: 1.5 m, 240Vac. outside the shower box).

DE- VERTEILERKASTEN

Bestmögliche Position für Verteilerkasten (1,5 m 240 VAC Kabel, außerhalb der Duschkabine).

FR- BOÎTE RÉCEPTEUR

Position hypothétique de la boîte de jonction dans le mur (câbles de 1,5 m, 240 Vac. l'extérieur de la cabine de douche).

IT- Ipotetica posizione per pulsantiera cromoterapia (cavo di 3m 12V).

EN- Hypothetical position for chromotherapy button panel (3m 12V cable).

DE- Hypothetische Position für das Chromotherapie-Tastenfeld (3 m 12 V-Kabel).

FR- Position hypothétique du panneau de boutons de chromothérapie (câble 12V 3m)



Norme CEI

IEC regulations

IEC-Normen

IT- Zona (3) d'installazione della scatola di derivazione.

EN- Installation area (3) for the junction box.

DE- Gebiet (3) der Installation des Verteilerkasten

FR- Zone d'installation (3) de la boîte de jonction.



IT - LA GARANZIA DEL PRODOTTO NON COPRE

L'utilizzo improprio.

L'errata predisposizione dell'impianto idraulico.

Danni causati da depositi di calcare o altre impurità.

Detergenti non adatti.

EN - NOT COVERED BY PRODUCT CARE

Not correct use.

Incorrect setup of the hydraulic system.

Water impurities or limestone deposits.

Improper detergents.

DE - DIE PRODUKTGARANTIE GILT NICHT

Die falsche Verwendung

Die falsche Anordnung des Hydrauliksystems.

Schäden durch Kalkablagerungen oder andere

Verunreinigungen.

Ungeeignete Reiniger.

FR - LA GARANTIE DU PRODUIT NE COUVRE PAS

Utilisation incorrecte.

La mauvaise disposition du système hydraulique.

Domages causés par des dépôts de calcaire ou

d'autres impuretés.

Nettoyants inappropriés.



IT - DUE ANNI DI GARANZIA DEL PRODOTTO

Contro i difetti o vizi di fabbricazione.

EN - TWO-YEAR PRODUCT CARE

Against defects of fabrication.

DE - ZWEI JAHRE LANG PRODUKTGARANTIE

Gegen Mängel oder Herstellungsfehler

FR - GARANTIE DE PRODUITS DE DEUX ANSO

Contre les défauts de fabrication.

IT - ATTENZIONE: Si declina ogni responsabilità relativa ad eventuali inesattezze contenute in queste istruzioni dovute ad errori di trascrizione.

EN - WARNING: We decline all responsibility for eventual inaccuracy contained in the instructions due to transcript errors.

DE - ACHTUNG: Wir lehnen jede Verantwortung für Ungenauigkeiten in diesen Anleitung aufgrund von Transkriptionsfehlern ab.

FR - ATTENTION: Nous déclinons toute responsabilité pour toute inexactitude contenue dans ces instructions en raison d'erreurs de transcription.

REMER
RUBINETTERIE

Remer Rubinetterie S.p.A.

20062 Via Leonardo da Vinci, 83 - Cassano d'Adda (MI) Italy

Tel. +39 0363 364211 - e-mail: info@remer.eu

www.remer.eu